

# FINITE ELEMENT METHOD IN CAR COMPATIBILITY PHENOMENA

**Marcin Lisiecki**

*Technical University of Warsaw  
Faculty of Power and Aeronautical Engineering  
Nowowiejska Street 24, 00-665 Warsaw*

*CRASH S.C. – Computer Research for Automotive Safety  
Kraśińskiego Street 71/50 Street, 05-120 Legionowo  
tel.: +48 22 7843621, fax: +48 22 7843621  
e-mail: marcin.lisiecki@crash.com.pl*

## **Abstract**

*The main aim of the study is the side impact of the truck into the passenger car, which is one of the possible variants in compatibility case. The compatibility problem has direct influence at biomechanical injuries of the passengers travelling by the cars and also at deformation of the structure. This research should assign critical configurations of the truck and the car during side impact. Critical criteria of compatibility problem are biomechanical injuries structure deformation. The research was performed with Chrysler Neon mode, automotive seating (metal construction), Hybrid III dummy model and moving barrier with changed mass (equals to the mass of the heavy truck KAMAZ) and equipped with front under run protection barrier (FUP - based on the geometry of the Mercedes ACTROS front structure). Interaction between car and heavy truck is at the driver side. During the research different location and angles of the barrier against the car has been taken into account. Two speeds were used to investigate the barrier influence to the car. The results of the simulation allow predicting the biomechanical coefficients such as: HIC, 3ms, TTI, e.g., which give the overview of the passenger injuries. The other set of the data is plastic deformations which are visible at the Front Underrun Protection (FUP) barrier and also at the passenger car construction. The results of research allows to assign the direction of the changes which should be proposed to the truck manufactures in order to reduce passengers biomechanical injuries and intrusion into car during side impact.*

**Keywords:** *compatibility, crash, biomechanics, simulation, transport*

## **1. Introduction**

The side impact of the car and the heavy truck can lead to occupant body injuries in passenger car. In order to reduce injuries among drivers and passengers we need to investigate their safety. That's why compatibility problem is so important in our live. The main reason to start this research was presence of the heavy truck on the road.

Since early 80's the number of the LTVs (Light Trucks and Vans) has increased considerably. This group contains vehicles of the gross weight up to 4 535.9 kg or less: light trucks, pickups, vans and SUVs. More vehicles which are in the LTVs group leads to develop new problems considering safety on the road. Among these we can list the relationships between:

- fatal case and increase of the LTVs number,
- cars characteristics and fatal collisions,
- drivers behaviour and fatal cases.

The reason of listed above is compatibility problem between vehicles with different mass, stiffness and geometry. These three factors are main components of the compatibility problem. Due to different construction of the cars their front or side safety areas do not match each other and that is the reason for which they cannot interact properly.

The car aggressivity is very important in the compatibility problem. The dependence (1) represents the influence of fatalities in collision partner to the number of crashes:

$$\text{Aggressivity} = \frac{\text{Fatalities in collision partners}}{\text{Number of Crashes of subject vehicle}}$$

The heavy trucks are present on our roads and cannot be replaced by other transport. The railroad, air or shipping transport is not available in all places. The trucks will be still needed to transport different kind of goods from one location to another, but those vehicles are more aggressive than passenger car as result from statistics and experiences show.

“On the French roads there is 50 times less truck than passenger cars, but for 1 276 fatal injuries 810 was caused by collision between car and truck”.

It has to be considered that trucks have a mass from 3 to 50 times greater than passenger cars and also stiffer front part. During the collision it causes the deformation of the passenger car.

## 2. Computer simulation

To investigate the influence of the compatibility problem between car and heavy truck the numerical simulations was performed. These simulations use Finite Element Method and PAM-CRASH 2G solver as an environment to build the models and scenarios. The solver module is PAM-SOLID solver and the analysis type is explicit. Units used in the model: kg, mm, ms and GPa. These units are mostly used for crash simulations. Elements used for barrier model are shell elements.

Material type is 103 – it is elastic-plastic material used for shell elements with Young’s modulus, Poisson’s ratio, hourglass coefficient. Materials 102/103 correspond to elastic-plastic thin shell material models, where Material Type 103 uses a plasticity algorithm that includes transverse shear effects thus exactly satisfying Hill's criterion and precisely updating the element thickness during plastic deformation. If the yield stress is defined on Card 3, the stress-strain curve is defined on Cards 4 and 5 via the plastic tangent modulus and plastic stress. Horizontal segments are then not allowed within the specified stress-strain curves (plastic deformation undetermined). Extrapolation beyond the last specified point is horizontal, however. Any number of points from 0 to 7 may be defined. Strain rate sensitive plasticity may be specified via up to 8 function curves on Function Cards. **Strain rate hardening.** No strain rate dependent hardening is applied if values STRAT1=STRAT2=0 on Card 6. Strain rate laws are given depending on parameter ISTRAT on Material Card 1a. All strain rate laws are available for this material. A GRUC (General Relative User Criterion) variable can be output if specified on the User Selected Shell Plot Output or User Selected Shell Time History Output Keyword Cards (CONTROL SECTION). The variable is defined on element and is non-dimensional. The output corresponds to the ratio 'value computed/value entered'. Auxiliary variables can be saved for plotting. Values 1 and 2 correspond to the maximal and minimal principal stresses per element within a certain time window, respectively. The time window is defined by the optional output control keyword **MEDSTRS**.

Models used in the simulations are:

- Chrysler Neon (shell and solid elements, standard PAM-CRASH data base),
- Moving barrier (solid elements, standard PAM-CRASH data base),
- Front Underrun Protection barrier (material is steel S500 and S600, depending on barrier part thickness is in the range 4-10 mm),
- Hybrid the III dummy (mainly shell elements, standard PAM-CRASH dummy data base),

The Chrysler neon model is a standard car model which exists in the PAM-CRASH 2G models database. The additional element is the metal seat structure on which the driver was settled down.

The moving barrier is the modified barrier from PAM-CRASH 2G database. The modification concerns the mass of the barrier and also the front part of it. Mass is equal 6 950 kg and is the mass of the KAMAZ heavy truck.

The front part of the moving barrier which is now the simplified model of the heavy truck was developed as finite element structure. The Front Underrun Protection barrier of the Mercedes Actros was used as base.

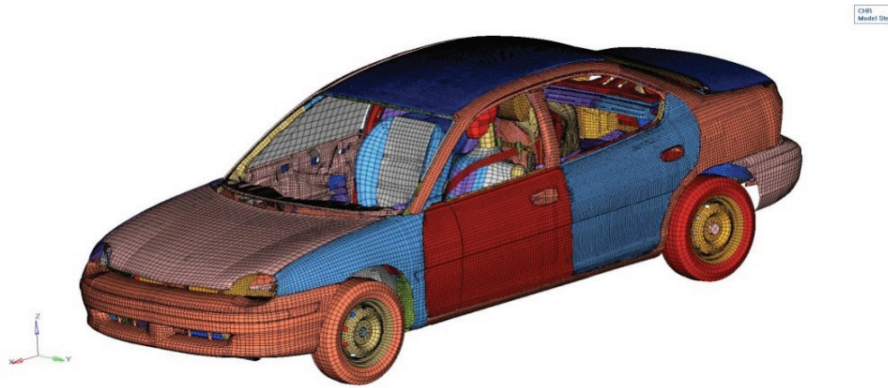

Fig. 1. The Chrysler Neon model with additional driver metal structure seat

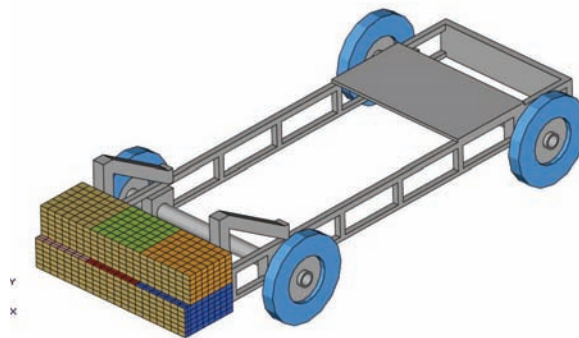

Fig. 2. Original moving barrier

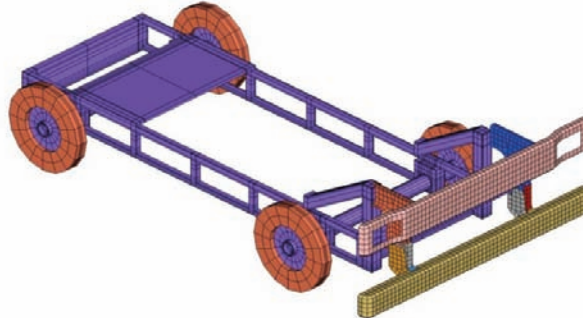

Fig. 3. Modified moving barrier

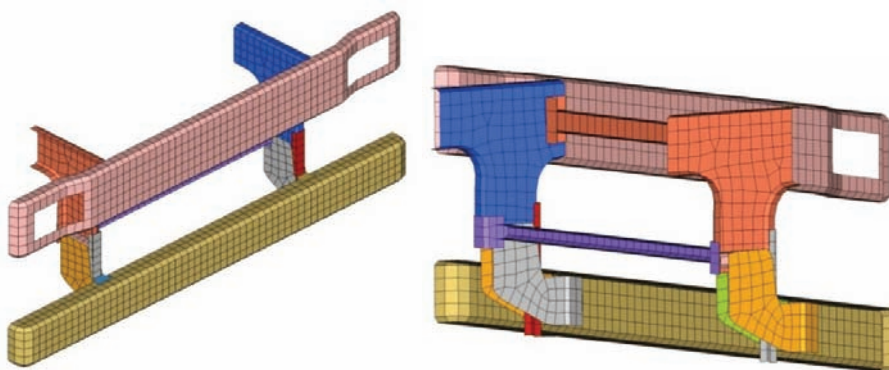

Fig. 4. The Finite Element Model of the Front Underrun Protection barrier

The simulations were done for two velocities: 51 km/h and 64 km/h with different positions, angles and heights of the front part of the moving barrier. The passenger car was still. Only the barrier was moving. The reference point is the central pillar of the passenger car. This part is in position 0. That

means if the barrier position is 0 mm in the relation to the central pillar of the car the moving barrier axis of the symmetry is central at the front of that part. All the considered cases are listed below.

The pictures shown below represent some of the cases from the above table. Yellow marks are the reference to the nominal position of the moving barrier. It means position 0 mm and angle 0°.

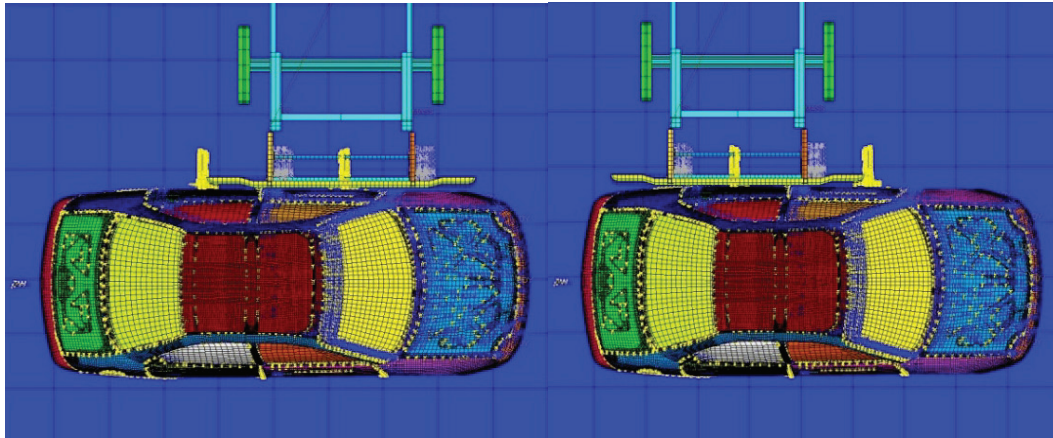

Fig. 5. Position of the moving barrier in the relation to the car

Tab. 1. The considered barrier and car configurations

Velocity [km/h]	Barrier Height above the ground [mm]	Position [mm]	Angle [°]
51	180	0	0
		-600	0
		+600	0
		-800	+20
		+800	-20
	300	0	0
		-600	0
		+600	0
		-800	+20
		+800	-20
	400	0	0
		-600	0
		+600	0
		-800	+20
		+800	-20
64	180	0	0
		-600	0
		+600	0
		-800	+20
		+800	-20
	300	0	0
		-600	0
		+600	0
		-800	+20
		+800	-20
	400	0	0
		-600	0
		+600	0
		-800	+20
		+800	-20

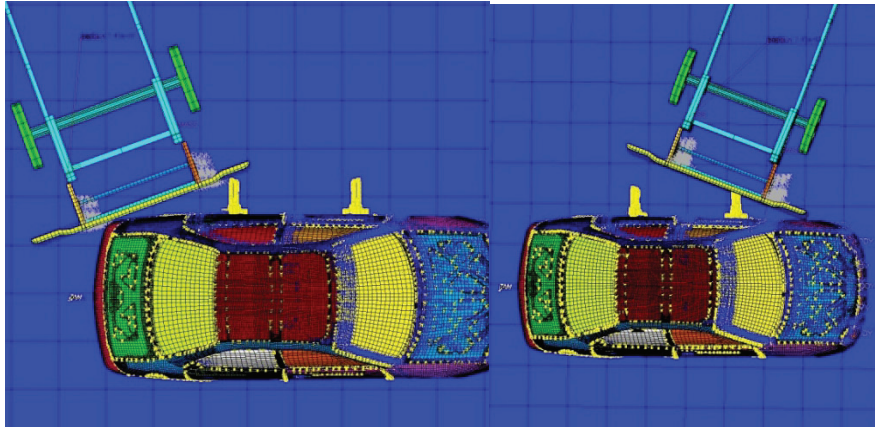

Fig. 6. Position of the moving barrier in the relation to the car

### 3. Results

First simulation was run with the use of the standard deformable barrier existing in the PAM-CRASH 2G model database. It was used only to evaluate how the model behaves and if all contacts between particular parts of the models are working properly. The second simulation was with the modified moving barrier. The modification was the change of the front deformable part of the moving barrier to the Front Underrun Protection barrier but without part which is needed to assemble the lights. Lack of this part leads to significant truck intrusion into construction of the passenger car. Especially the windshield pillar and the driver doors were affected.

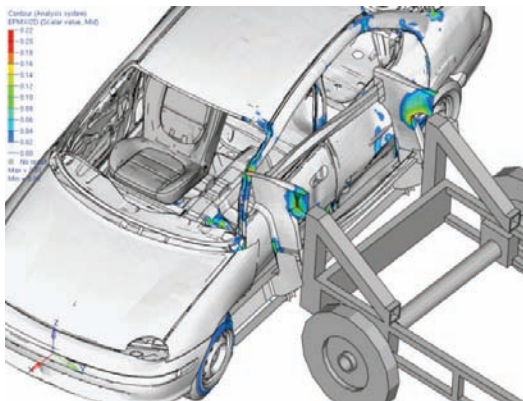

Fig. 7. Moving barrier without lights assembler part – plastic strains

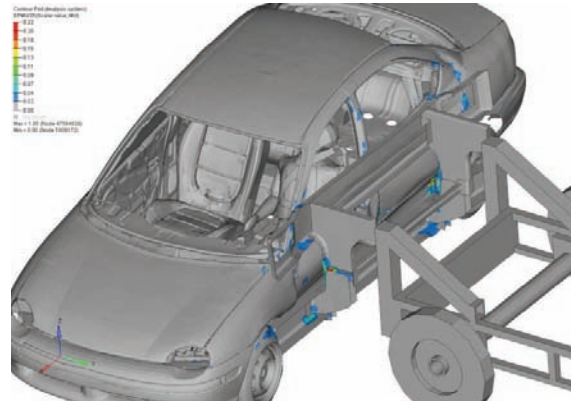

Fig. 8. Plastic Strains – velocity 51km/h, height 300m, position 0, angle 0

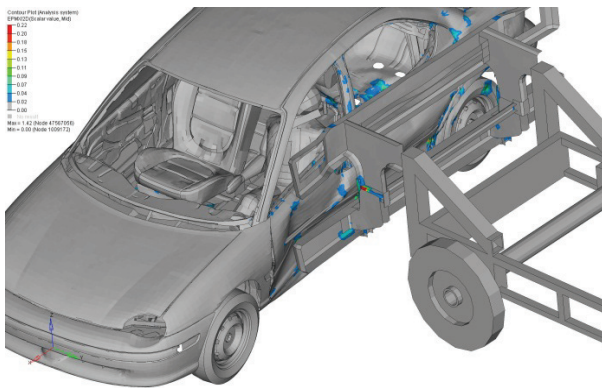

Fig. 9. Plastic Strains – velocity 51km/h, height 300m, position -600, angle 0

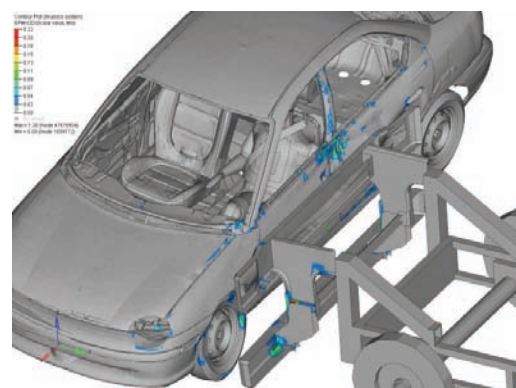

Fig. 10. Plastic Strains – velocity 51km/h, height 300m, position +600, angle 0

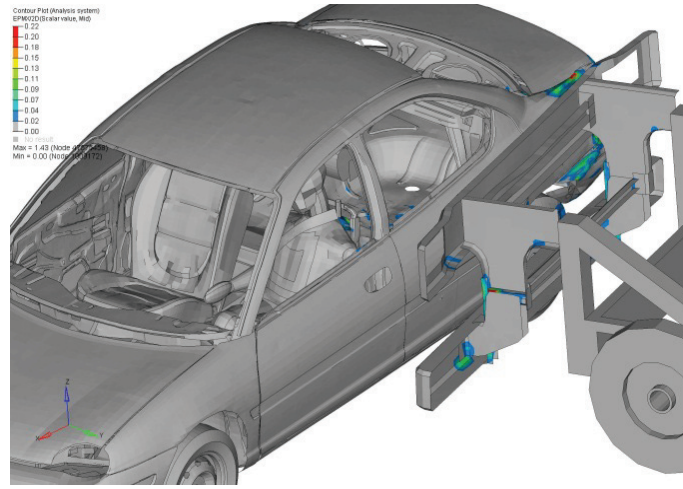
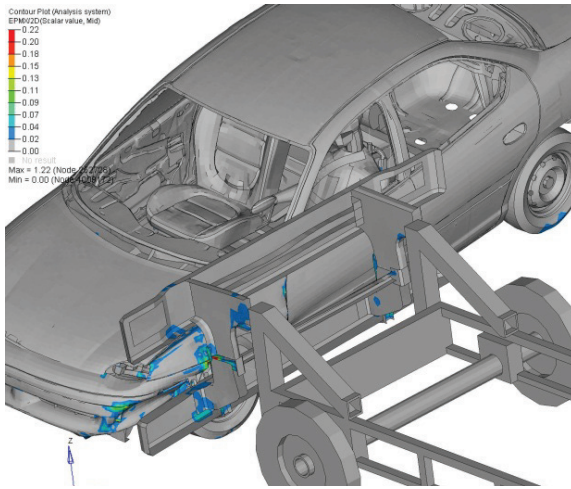

Fig. 11. Plastic Strains – velocity 51km/h, height 300m, position +800, angle -20, Fig. 12. Plastic Strains – velocity 51km/h, height 300m, position -800, angle +20

Next simulations were performed with the moving barrier equipped with the part needed for the lights. These simulations allow investigating the influence of the side impact of the heavy truck into the passenger car. Maximum plastic strains which appear during the simulation are in the range 105% - 143%. The maximum plastic strains for the steel is around 22%. Above this value steel part will be destroyed. The maximum plastic strains occur in the front underfund protection barrier and also in the bottom side of the passenger car.

During these experiments the following significant biomechanical injury criteria were investigated:

- HIC (Head Injury Criteria which critical value is 1 000, above it occupant will be dead),
- FNIC (criteria which describes neck injuries),
- 3 ms (criteria which describes maximum linear acceleration of the human chest, critical value is 60 g),
- FFC (describes femur injuries)
- VC (acceleration of the internal human organs, value is tolerate equals 1 m/s)

$$HIC = \left[ \frac{1}{t_2 - t_1} \int_{t_1}^{t_2} a dt \right]^{2,5} (t_2 - t_1), \quad (1)$$

where:

HIC - Head Injury Criteria,

a - dummy head acceleration,

$t_2, t_1$  - end and start time of the HIC calculation.

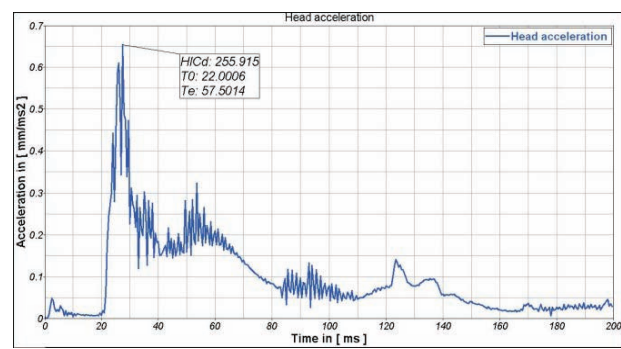
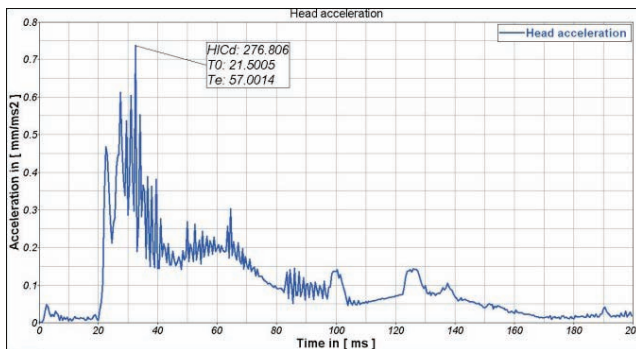

Fig. 13. HIC factor - velocity 51km/h, height 300m, position 0, angle 0

Fig. 14. HIC factor - velocity 51km/h, height 300m, position -600, angle 0

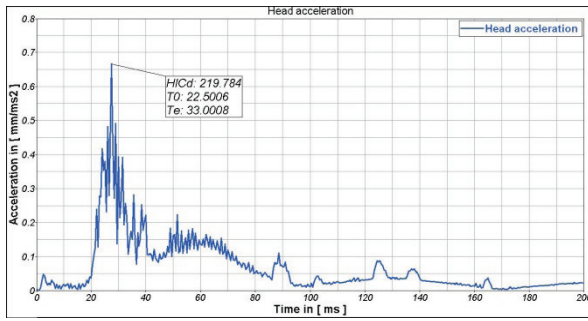

Fig. 15. HIC factor - velocity 51km/h, height 300 m, position +600, angle 0

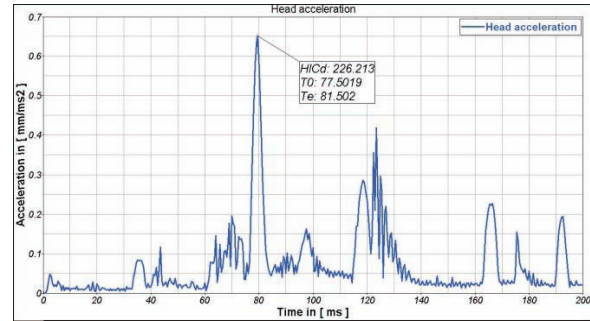

Fig. 16. HIC factor - velocity 51km/h, height 300 m, position +800, angle -20

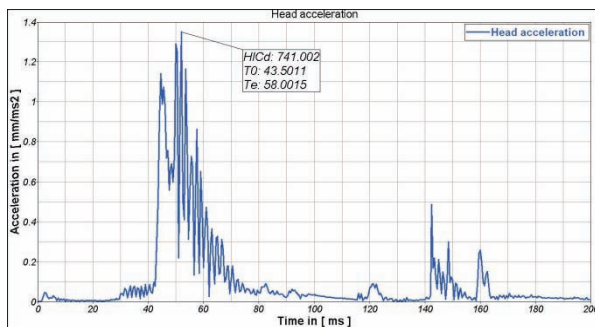

Fig. 17. HIC factor - velocity 51km/h, height 300 m, position -800, angle +20

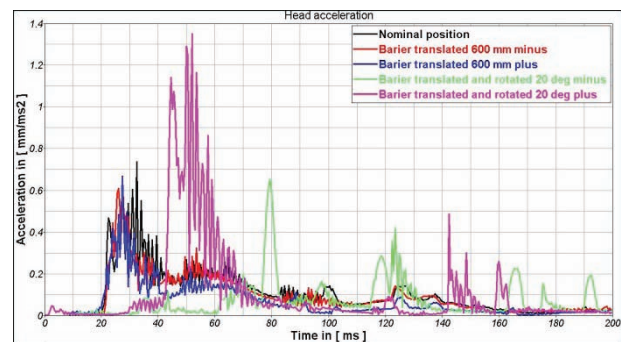

Fig. 18. HIC factor - summary

#### 4. Conclusions

The compatibility problem between the passenger car and the heavy truck during the side impact exists. It is caused by the different mass, the stiffness and the height of the cars. Different position of the front part of the truck gives the different interaction between the car and the truck.

Most dangerous case occurs when front part of the truck is located high in the relation to the low part of the car. In this case the front underrun protection barrier does not interact properly with the door and the low part of the passenger car. This leads to the significant plastic deformation in both vehicles.

The plastic strains shows that bottom part of the passenger car and the truck front underrun protection barrier will be destroyed during the collision. This allows us to conclude that safety zones of the truck and the car are not working properly together.

Analyzing the biomechanical injury criteria we can conclude that the significant factor is: HIC which refer to the head of the occupants. Especially the head and neck are mostly at risk. Results for the HIC factor, shown above, are in the range 219 up to 741. It means that in the worst case for the velocity 51 km/h and the HIC value 741 the driver of the passenger car can die. When the HIC factor is around 200 up to 400 the occupant will survive, but the head and the neck can be injured seriously.

#### References

- [1] Kajzer, J., Harada, Y., *Compatibility between Trucks and Cars in road accidents*, Seminar / Workshop Biomechanics of Impacts / Passive Safety Problems in Central and Eastern Europe, Warsaw 2001.
- [2] *Special issue: Vehicle compatibility in crashes*, Status Report, Vol. 34, No. 9, 1999.
- [3] ESI Group, *Virtual Performance Solution 2008 Explicit Solver Notes Manual*, 2008.